



# XAAR XUSB Drive Electronics

## Xaar XUSB Drive Electronics

Easy-to-integrate solution

Ultimate in scalability  
and flexibility

Reduced time-to-market

## High performance printhead data management

The Xaar XUSB Drive Electronics (DE) provides a flexible, cost-effective, easy-to-integrate solution designed to drive Xaar's complete range of market leading printheads. The XUSB DE minimises the cost and resources issues faced by OEMs and inkjet innovators when developing bespoke printers, and thereby drastically reduces time-to-market.

Ideal for use as part of a developer kit or fully integrated into production printers for emerging industrial applications, the compact and robust electronics component can be controlled via a standard PC or laptop to enable quick and easy integration.

Industry standard USB 2.0 connectivity ports allows off-the-shelf switches and network cards to be used to reliably network XUSBs together and enhance performance from the external PC. The proven hardware and software package used with the XUSB ensures optimal printhead operation, reduces time-to-market and minimises the costs involved with developing industrial printers.

Xaar is a world-leader in the development and manufacture of industrial inkjet technologies with over 20 years' experience. The company is headquartered in the UK, has state-of-the-art manufacturing facilities in Europe and exports its printheads to manufacturers around the world.

# Xaar XUSB Drive Electronics

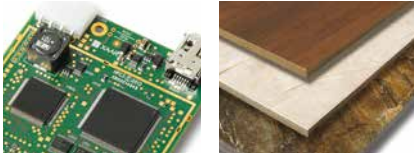

## Driving success

The XUSB DE is a key element to the success of the digital inkjet process, providing the conduit between the data processed image and the Xaar printhead. Using its extensive industry experience, Xaar has engineered a production specification system for OEMs and inkjet innovators that removes the fundamental issues associated with electronic design, system compatibility and engineering resource availability.

The Xaar XUSB DE system, which is fully CE certified, offers customers peace of mind and an easy path to developing inkjet applications for new and existing market.

## Flexible and cost-effective

The compact and modular system, which is ideal for machine designs where space is at a premium, is capable of driving up to eight printheads via a USB 2.0 port on a PC or laptop. With minimal software development, up to 12 XUSB boxes can be integrated and controlled by a single computer to support up to a maximum of 96 printheads (depending upon type).

Designed to promote versatility, the XUSB DE system is easily adapted to meet complex printhead layout architectures, enabling the integrator to develop a printhead configuration that best meets their needs.

## Compatibility

The XUSB DE solution is supplied with a demonstration application, requiring Photoshop software, to illustrate its capability. It is also optimised to drive eight of the Xaar 1003 printheads, utilising the Xaar Head Personality Card (HPC3) for each printhead.

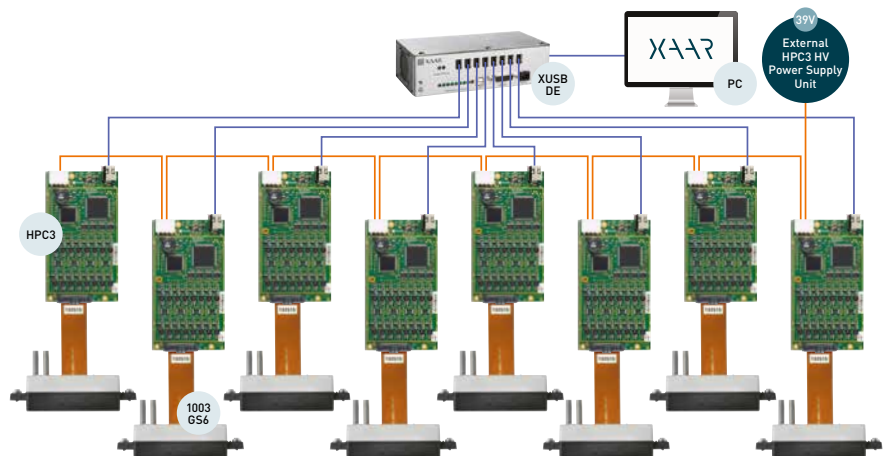

Specification	XUSB DE
Maximum number of printheads	8
Printhead types supported	Xaar 1001, Xaar 1002, Xaar 1003 and Xaar 501
Print buffering memory	512 MB per Xaar XUSB
Product detect inputs	1
Shaft encoder inputs	1
Operating modes	Single shot, back to back, fixed gap continuous (all with optional soft stop)
Variable data support	Yes, streaming
Weight	664 g
Dimensions (WxDxH)	174x85x52 mm
Supply voltage*	24-30 V
Supply power rating*	Up to 28 A
Printhead maintenance	Printhead power control and idle spit
Application types	Uni/Bi-directional scanning, single-pass web and labelling
Operating system support	32 and 64 bit Windows 7 and Windows 8
Programming interface	Xaar Scorpion API via Windows DLL

\*Dependent on system integration



Head Office / Europe  
+ 44 1223 423 663  
info@xaar.com

Hong Kong  
info@xaar.com

USA  
+ 1 972 606 2520  
americas@xaar.com

www.xaar.com