



PCT

WORLD INTELLECTUAL PROPERTY ORGANIZATION  
International Bureau

## INTERNATIONAL APPLICATION PUBLISHED UNDER THE PATENT COOPERATION TREATY (PCT)

<p>(51) International Patent Classification<sup>6</sup> : <b>B65H 5/22, 29/24</b></p>	<p><b>A1</b></p>	<p>(11) International Publication Number: <b>WO 99/11551</b></p> <p>(43) International Publication Date: 11 March 1999 (11.03.99)</p>
<p>(21) International Application Number: PCT/GB98/02654</p> <p>(22) International Filing Date: 4 September 1998 (04.09.98)</p> <p>(30) Priority Data: 9718848.6 4 September 1997 (04.09.97) GB 9815504.7 16 July 1998 (16.07.98) GB</p> <p>(71) Applicant (for all designated States except US): XAAR TECHNOLOGY LIMITED [GB/GB]; Science Park, Cambridge CB4 4FD (GB).</p> <p>(72) Inventors; and (75) Inventors/Applicants (for US only): TEMPLE, Stephen [GB/GB]; Xaar Technology Limited, Science Park, Cambridge CB4 4FD (GB). BUTLER, Keith, Patrick [GB/GB]; Xaar Technology Limited, Science Park, Cambridge CB4 4FD (GB). MANNING, Howard, John [GB/GB]; Xaar Technology Limited, Science Park, Cambridge CB4 4FD (GB). DIXON, Michael, John [GB/GB]; Xaar Technology Limited, Science Park, Cambridge CB4 4FD (GB).</p> <p>(74) Agents: CROPP, John, Anthony, David et al.; Mathys &amp; Squire, 100 Grays Inn Road, London, WC1X 8AL (GB).</p>		<p>(81) Designated States: AL, AM, AT, AU, AZ, BA, BB, BG, BR, BY, CA, CH, CN, CU, CZ, DE, DK, EE, ES, FI, GB, GE, GH, GM, HR, HU, ID, IL, IS, JP, KE, KG, KP, KR, KZ, LC, LK, LR, LS, LT, LU, LV, MD, MG, MK, MN, MW, MX, NO, NZ, PL, PT, RO, RU, SD, SE, SG, SI, SK, SL, TJ, TM, TR, TT, UA, UG, US, UZ, VN, YU, ZW, ARIPO patent (GH, GM, KE, LS, MW, SD, SZ, UG, ZW), Eurasian patent (AM, AZ, BY, KG, KZ, MD, RU, TJ, TM), European patent (AT, BE, CH, CY, DE, DK, ES, FI, FR, GB, GR, IE, IT, LU, MC, NL, PT, SE), OAPI patent (BF, BJ, CF, CG, CI, CM, GA, GN, GW, ML, MR, NE, SN, TD, TG).</p> <p><b>Published</b> With international search report.</p>

(54) Title: VACUUM DRUMS FOR PRINTING, AND DUPLEX PRINTERS

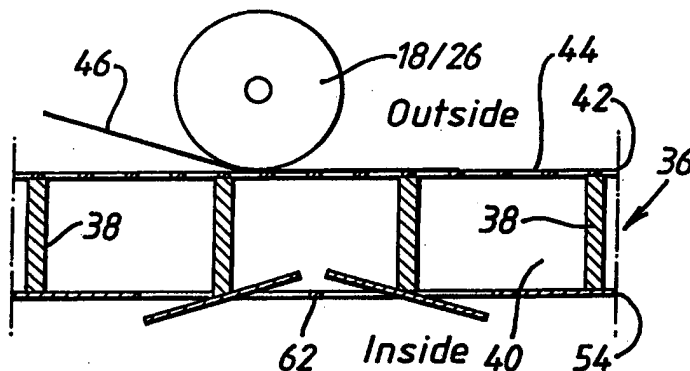

## (57) Abstract

A vacuum drum assembly for a printing machine comprises a drum having an array of passageways (40) distributed along its length and around its periphery to permit air to flow from outside the drum to inside the drum in response to reduced air pressure inside the drum, and an array of valve members (52), each valve member being movable between a closed position in which that valve member restricts at least one of the passageways and an open position in which the restriction of that passageway or those passageways is reduced. The arrangement is such that, when a partial area of the drum is wrapped with a sheet of material, at least some of the valves for the passageways adjacent the edges of that area are open, and the valves for the passageways which are not covered by the sheet and are not adjacent the edges of that area are closed. The open area of the drum is regulated such that it is small in regions where there is no paper. Accordingly, the open area of the drum is adapted to the shape and size of the paper and the position of the paper on the drum, whilst minimizing the required suction flow. A duplex printing machine comprises two such vacuum drum assemblies with their drums parallel. The air pressure inside the drums is reduced and the drums are counter-rotated. Material to be printed on is fed to the first drum so that the material can be held on the first drum by vacuum and rotated therewith, and a first print head prints on one side of the material. The material is then released from the first drum in a direction towards the second drum so that the material can be held on the second drum by vacuum and rotated therewith. A second print head then prints on the material on the second drum. The material is then released from the second drum.