



XAAR Inkjet Development System

Xaar Inkjet Development System

Proven, de-risked solution

Reference design source code

Reduced time-to-market

A flexible kit for you to test, analyse and develop with inkjet

The Xaar Inkjet Development System is a cost effective method to prove a desired print process for a wide range of applications and requirements on various new or existing equipment.

Containing the inkjet components necessary to build a fully functional prototype system, this kit comprises of your selected choice of Xaar printheads, a mechanical mounting kit, drive electronics, ink supply system, print server and Xaar test fluid.

With this kit, developers can create an inkjet solution ready to evaluate inkjet without needing to redesign critical components yourself which can be complex, involving the interaction of many physical, chemical, mechanical, electrical and software parameters.

This kit is ideal if you're looking to develop a new manufacturing process, populate a prototype machine, test jetting fluids, develop image quality models and much more.

It can be used with a range of analysis tools such as a dropwatcher and plotter to evaluate various factors such as resolution, fluid viscosity and ink recirculation.

Xaar Inkjet Development System

The Xaar Inkjet Development System will help you answer the following questions:

- What is the jetting behaviour of my fluid?
- What resolution does my application need?
- How easily does a Xaar printhead integrate with my current equipment?
- What image quality can I achieve with a Xaar printhead?
- I want to test and develop for my own datapath, is it possible with the Inkjet Development System?
- How does my fluid interact with my substrate?

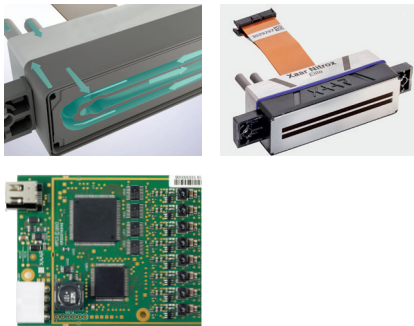

Included in the kit:

- **Printheads**, choose between Xaar Nitrox, Xaar Aquinox, Xaar 2002, Xaar 501 and Xaar 502 (typically 1 or 4 + different drop sizes are available, depending on the application requirements)
- **Mechanical Mounting Kit** (printhead mount for all TF Technology enable/ImagineX printheads (1 printhead, XY adjustment), HPC mount, Hydra manifold mount)
- **Drive Electronics** (Xaar Print Manager (XPM) & Head Personality Card (HPC) or 3rd party partner)
- **Ink Supply System** (Xaar Hydra or Megnajet IDS)
- **Xaar Print Manager** software (XPM Suite)
- **Xaar Test Fluid**.

Not included in the kit:

- Graphical User Interface (GUI)
- Workflow
- RIP
- Curing
- Encoder
- Product detect.

Illustrative diagram for a typical development system

This sample Inkjet Development System is using Xaar 2002 GS12 printheads and the XPM drive electronics. Different drop sizes for the Xaar 2002 printheads are available depending on the application requirements.

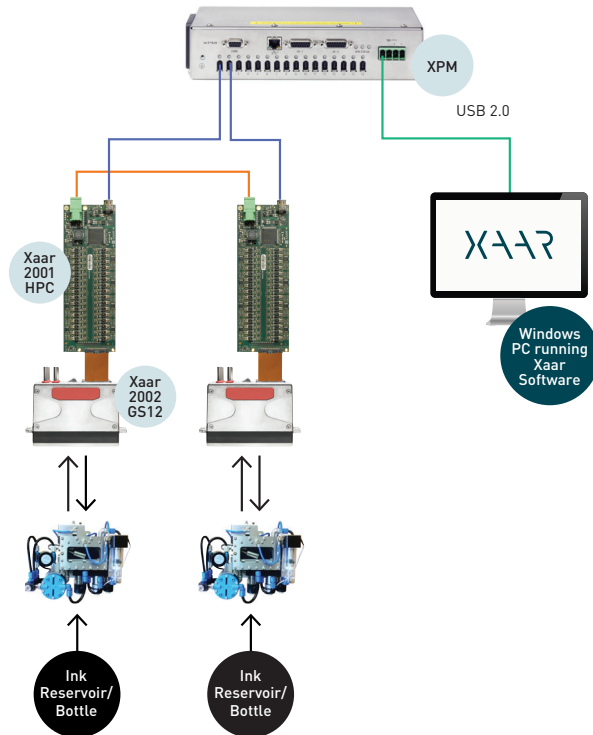

Xaar Inkjet Development System: Sample Specification

Xaar 2002 printheads	2	Refer to the Xaar 2002 printhead datasheet for further details
Head Personality Cards	2	One per printhead; 4.5m firewire cable supplied
XPM	1	Drives up to 16 printheads, cables supplied
XPM Power Supply	1	One per XPM
Ink Supply System	2	One system required for each ink colour/fluid type



Head Office / Europe
+ 44 1223 423 663
info@xaar.com

Asia
+86 755 23309293
info@xaar.com

USA
americas@xaar.com

www.xaar.com